

MODULE TOP **MT1**

DATASHEET

18 w

For 102 dBA
equivalent*

< 150 W	A +
150 à 300 W	A
301 à 500 W	B
501 à 1000 W	C
1001 à 1500 W	D
>1500 W	E

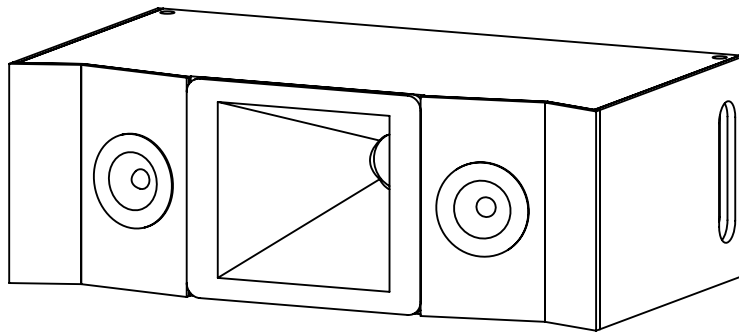

MT1



**CONSTANTE
DIRECTIVITY**



**VERY HIGH
EFFICIENCY**



**MEDIUM
THROW**

INTELLIGIBILITY AND LOW DISTORTION

Transparent and warm listening experience

CONSTANT DIRECTIVITY

Uniform 60° dispersion

DOWN TO 500 HZ

4" coil and titanium dome

DESIGNED FOR TOURING

Handles, rigging system, pole mounts

ACOUSTIC FEATURES

- Mid-High Speaker
- Two-way system / Passive filtering
- Two Speakon 2-point IN and OUT
- Dual pole mountable
- 9mm birch plywood
- Marine varnish finish
- Handles / 35mm pole socket / Epoxy-coated steel grille

TYPE	Exponential mid-high horn
TRANSDUCERS	2" compression driver - 100mm voice coil - neodymium pure titanium diaphragm
FREQUENCY RESPONSE	500 - 20 000 Hz (+/-3 dB)
CONTINUOUS POWER HANDLING	540 W (nominal program power capacity + 3 dB)
ACOUSTIC EFFICIENCY	18 W (for 102dBA equivalent*)
SENSITIVITY	109 dB (at 1 W constant, 1 m) 111 dB (at 2 V constant, 1 m)
MAX SPL	138 dB SPL (@1m, pink noise 6 dB crest factor)
DISPERSION	60° x 40° (H° X V° / -6 dB)
IMPEDANCE	8 ohms
DIMENSIONS (LXPXH)mm	680x370x236
WEIGHT	14 kg
OTHER	2x 35mm Pole Socket / Speakon 2-point IN & OUT Monoblock Handles / Padded Velcro Cover

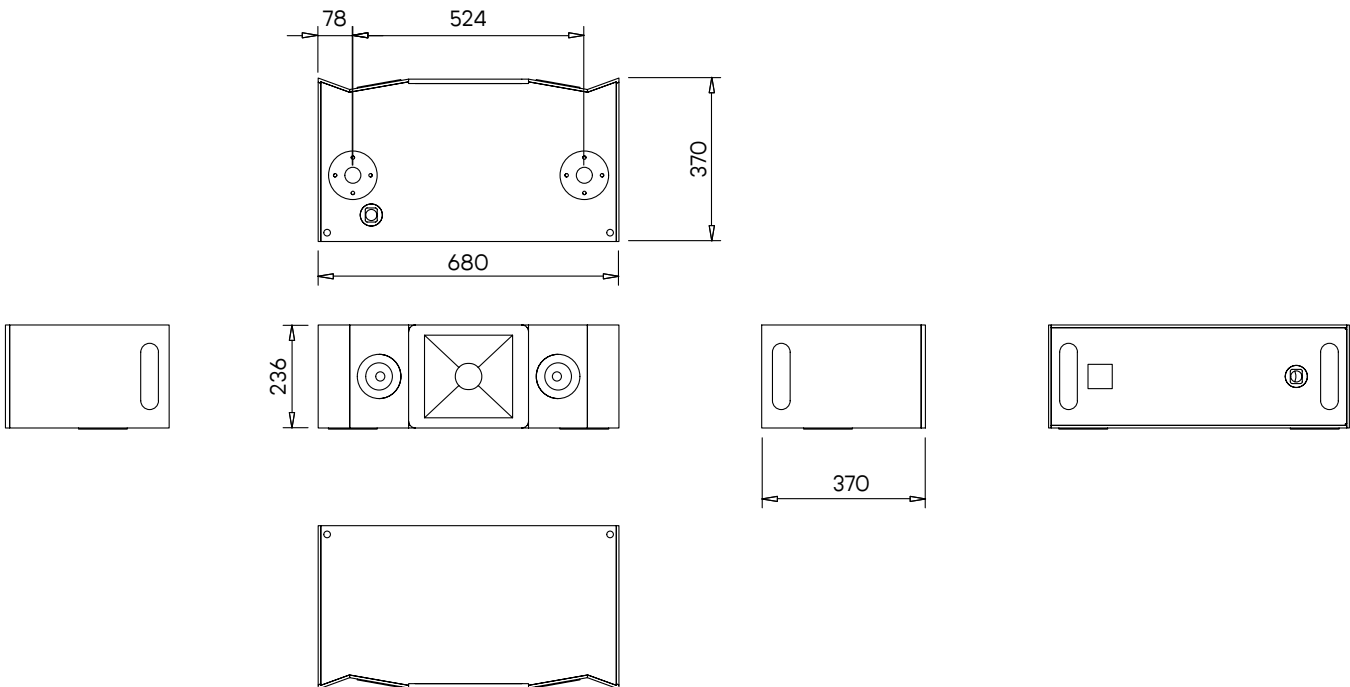

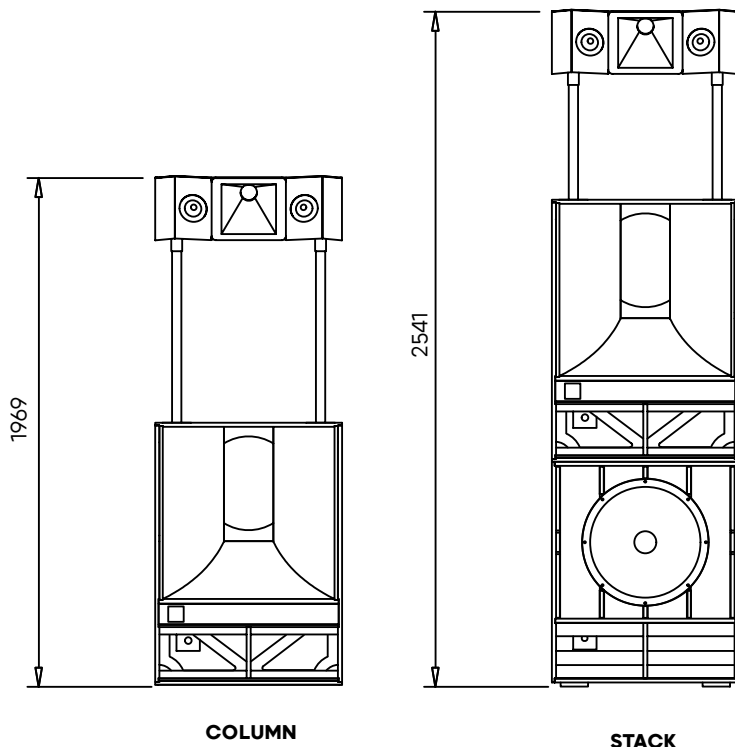

ACOUSTIC EFFICIENCY LABEL

*The figure given represents the electrical power dissipated by the speaker to generate over its bandwidth a sound level equivalent to 102 dBA with a pink noise input. For calculation purposes, the speaker is considered being part of an equalized system with absolutely flat response from 20 Hz to 20 kHz.

The calculation method is linear and does not take into account high power non-linear phenomena. Calculation details are available in the paper Quantifying Loudspeakers' Power Consumption, published in the AES journal (July/August 2022, Vol 70 no 7/8).



PASSIVE SPEAKERS



*The figure given represents the electrical power dissipated by the speaker to generate over its bandwidth a sound level equivalent to 102 dBA with a pink noise input. For calculation purposes, the speaker is considered being part of an equalized system with absolutely flat response from 20 Hz to 20 kHz.

The calculation method is linear and does not take into account high power non-linear phenomena. Calculation details are available in the paper Quantifying Loudspeakers' Power Consumption, published in the AES journal (July/August 2022, Vol 70 no 7/8).